

## Designing periodic topologies of structures under self-weight load

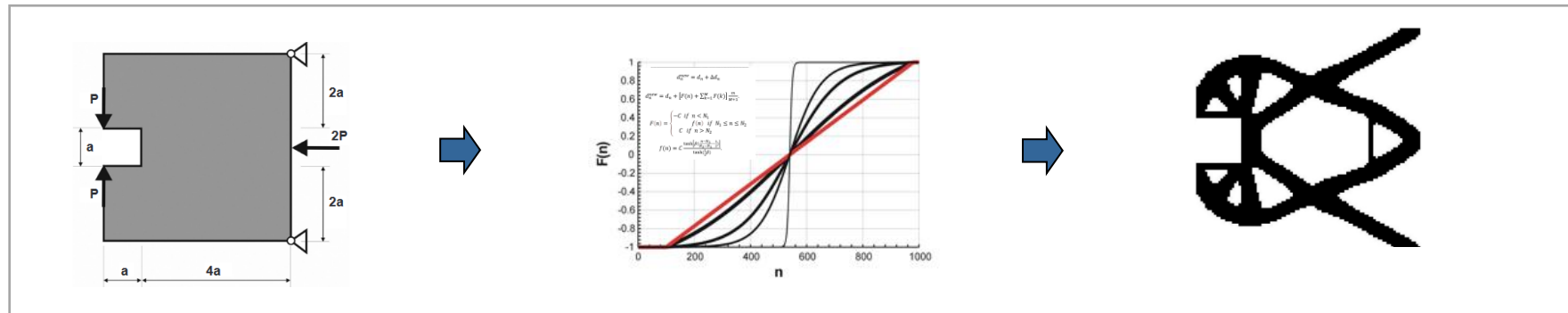

Katarzyna Tajs-Zielińska

Cracow University of Technology, Poland

Corresponding author e-mail: [katarzyna.tajs-zielinska@pk.edu.pl](mailto:katarzyna.tajs-zielinska@pk.edu.pl)

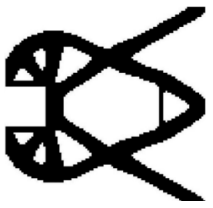

# Outline

---

- Topology optimization problem formulated as a minimization of a structure compliance
- Cellular Automata as an optimization tool
- Flexible Cellular Automata rules that is how to generate structural topologies in an efficient way
- Topology optimization of periodic structures
- Introductory example
- Results of Topology Generation using Cellular Automata rules
- Conclusions

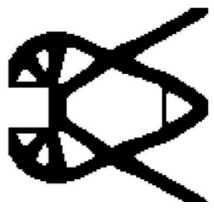

# Topology optimization problem formulated as a minimization of a structure compliance

- The principle of the topology optimization is to find within a design domain the distribution of material that is optimal in some sense.
- The design domain is represented by finite elements and design variables are selected for these elements.
- The distribution of the optimal design variables is used to create the resulting topology.
- During optimization process material is redistributed and parts that are not necessary from objective point of view are selectively removed. This fulfills a typical constraint which limits the amount of material that may be present in the final solution.

**Minimization of compliance subject to a total volume constraint**

**Minimization of compliance** (set locally for each cell)

$$\text{minimize} \quad U(d_i) = d_i^p \mathbf{u}_i^T \mathbf{k}_i \mathbf{u}_i$$

$$\text{subject to} \quad 0 < d_{\min} \leq d_i \leq 1$$

**Total volume constraint** (set globally, checked after each iteration)

$$V(\mathbf{d}) = \kappa V_0$$

$E_i = d_i^p E_0$  **SIMP approach** Solid Isotropic Material with Penalization

$E_0, d, p$  The Young modulus and material density of a cell modelled as functions of relative density

Elastic modulus, relative density of material and penalization power

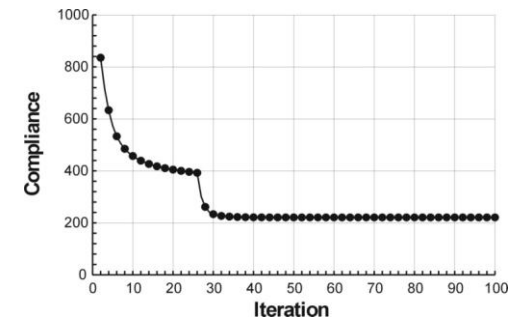
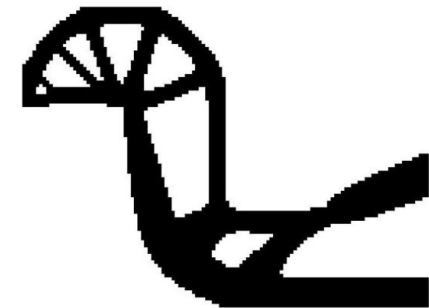
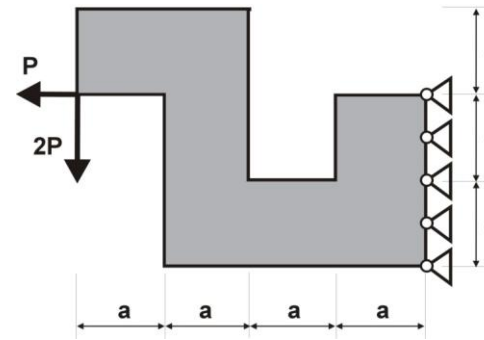

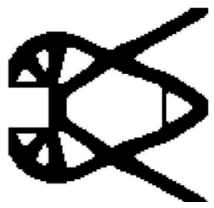

# Topology optimization problem formulated as a minimization of a structure compliance

---

**Gradient-based methods** (optimality criteria algorithm)

## **Heuristic methods**

- Genetic Algorithm
  - Ant Colony Methodology
  - Simulated Annealing
  - Binary Particle Swarm Optimization
  - Probabilistic Learning
  - Heuristic Algorithm Mimicking a Self-evolution of a Structure
  - Big Bang–Big Crunch Algorithm
  - and recently published Hunter-Prey Optimization Algorithm
- 
- Cellular Automata

1. Kaveh, A. et al. Structural topology optimization using ant colony methodology. *Engineering Structures* **2008**, *30*(9), 2559-2565.
2. Kane, C.; Schoenauer, M. Topological optimum design using genetic algorithms. *Control Cybern* **1996**, *25* (5), 1059-1088.
3. Najafabadi, R. H.; Goto, G. T.; Falheiro, M.S.; Martins, C. T.; Barari, A.; S. G. Tsuzuki, M. Smart Topology Optimization Using Adaptive Neighborhood Simulated Annealing. *Appl. Sci.* **2021**, *11*, 5257.
4. Luh, G.-C.; Lin, C.-Y.; Lin, Y.-S. A binary particle swarm optimization for continuum structural topology optimization. *Applied Soft Computing* **2011**, *11*, 2833–2844.
5. Valdez, S.I. et al. A meta-heuristic for topology optimization using probabilistic learning. *Appl Intell* **2018**, *48*, 4267–4287.
6. Chen, R. Heuristic algorithm for topology optimization of continuum structure. *Journal of Discrete Mathematical Sciences and Cryptography* **2018**, *6*, 1379-1384.
7. Ahn, HK.; Han, DS.; Han, SY. A Modified Big Bang–Big Crunch Algorithm for Structural Topology Optimization. *Int. J. Precis. Eng. Manuf.* **2019**, *20*, 2193–2203.
8. Zhao, Z.; Rui, Y.; Liu, Y.; Liu, Z.; Tu, Z. Topology Optimization of Continuum Structures Based on Binary Hunter-Prey Optimization Algorithm. *Symmetry* **2023**, *15*, 1118.

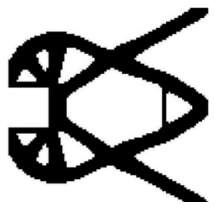

# Cellular Automata as an optimization tool

Among biologically inspired optimization techniques that have recently gained more attention are **Cellular Automata**.

**Cellular Automaton (CA) is a mathematical idealization of a physical system in which the design domain is divided into a lattice of cells, states of which are updated synchronously in discrete time steps according to some local rules.**

The principle of CA is that global behavior of the system is governed by cells that only interact with their neighbors. **This is analogous to the behavior of biological tissues.**

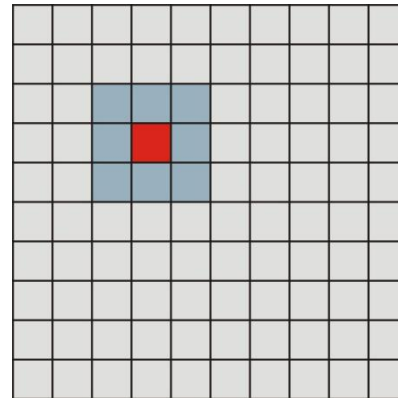
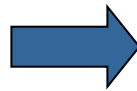
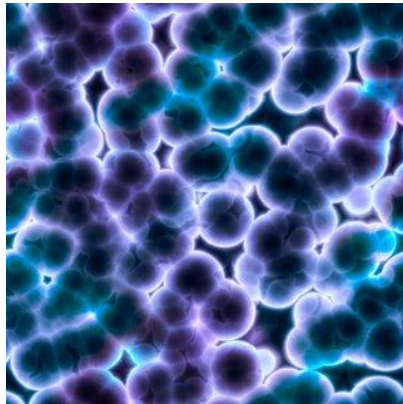

**The engineering implementation** of CA requires decomposition of considered domain into a set of cells which form a uniform lattice. A particular cell together with cells to which it is connected make up a **neighborhood**. It is assumed that the cells interact only within their neighborhood.

The evolution of state is governed by a **local update rule**. The rules are identical for all cells and are applied simultaneously to each of them. By applying the rules repetitively to locally updated physical quantities the process converges to a description of the global behavior of the system.

The characteristic feature of CA which is modelling of complex systems by simple local rules has attracted researchers from various disciplines like physics, biology, social sciences, transport or logistics.

The concept of Cellular Automaton was introduced in the middle of 20th century.

1. Von Neumann J., (1966): Theory of self-reproducing automata, University of Illinois Press, Urbana IL.
2. Ulam S., (1952): Random processes and transformations, Proceedings of the Int. Congress of mathematics, 2, 85-87.

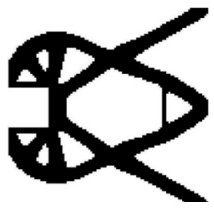

# Cellular Automata as an optimization tool

**The Cellular Automata can be used as optimization tool. The method has been found attractive because of its simplicity and versatility.**

Inou N., Shimotai N., Uesugi T. (1994), A cellular automaton generating topological structures, Proceedings of the 2<sup>nd</sup> European Conference on Smart Structures and Materials, 2361, 47-50.

Bochenek B., Tajs-Zielińska K. (2012), Novel local rules of Cellular Automata applied to topology and size optimization, Engineering Optimization, Vol. 44 Iss: 1, pp. 23-35.

**The CA approach to structural optimization allows formulation of both optimal sizing and topology optimization problems.**

## **Motivation Why Cellular Automata?**

### **A fast convergent technique**

The main advantage of the developed CA algorithm is that it is a fast convergent technique and usually requires far less iterations as compared to other approaches to achieve the solution.

### **Simplicity and versatility**

There are not many parameters to adjust.

### **Easy application**

Presented algorithm is quite general what allows its easy application to 3D problems. The local update rules are simple so they can be easily implemented into professional FEM analysis codes, allowing for solving practical engineering optimization problems.

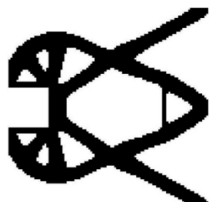

# Cellular Automata as an optimization tool

## Update rule

$$d_i^{new} = d_i + \Delta d_i$$

$$\Delta d_n = \left[ a_0 \alpha_n + \sum_{k=1}^M \alpha_k \right] \frac{m}{M+1}$$

$$\alpha_n = \begin{cases} -C_\alpha & \leftarrow c_n \leq c^* \\ C_\alpha & \leftarrow c_n > c^* \end{cases}$$

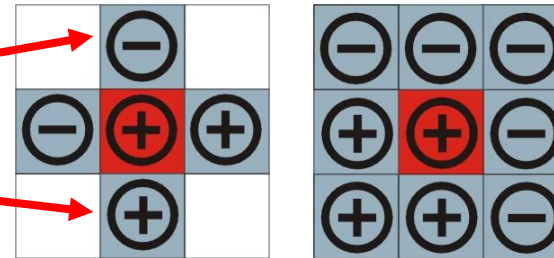

$$\max(d_{\min}, d_n - m) \leq d_n^{new} \leq \min(1, d_n + m)$$

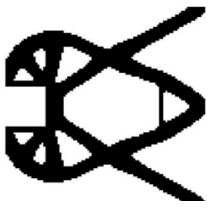

# Cellular Automata as an optimization tool

## Update rule

$$F(n) = \begin{cases} -C_\alpha & \leftarrow n \leq N^* \\ C_\alpha & \leftarrow n > N^* \end{cases}$$

$$\Delta d_n = \left[ a_0 F(n) + \sum_{k=1}^M F(k) \right] \frac{m}{M+1}$$

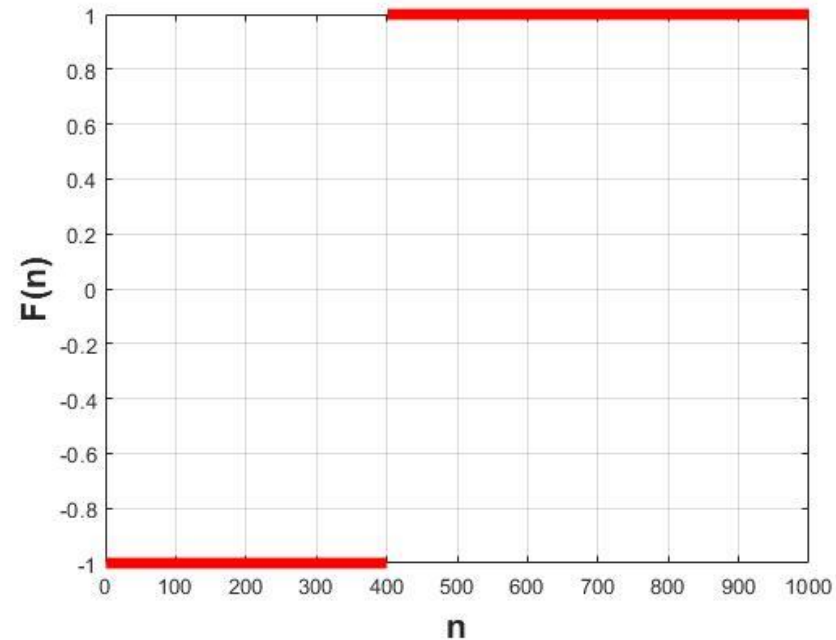

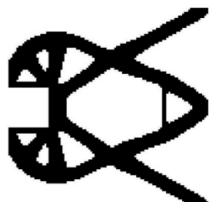

# Cellular Automata as an optimization tool

## Update rule

$$N^* \rightarrow N_1, N_2$$

$$F(n) = \begin{cases} -C_\alpha & \leftarrow n < N_1 \\ f(n) & \leftarrow N_1 \leq n \leq N_2 \\ C_\alpha & \leftarrow n > N_2 \end{cases}$$

$$f(n) = \frac{2n}{N_2 - N_1} - \frac{N_2 + N_1}{N_2 - N_1}$$

$$\Delta d_n = \left[ a_0 F(n) + \sum_{k=1}^M F(k) \right] \frac{m}{M+1}$$

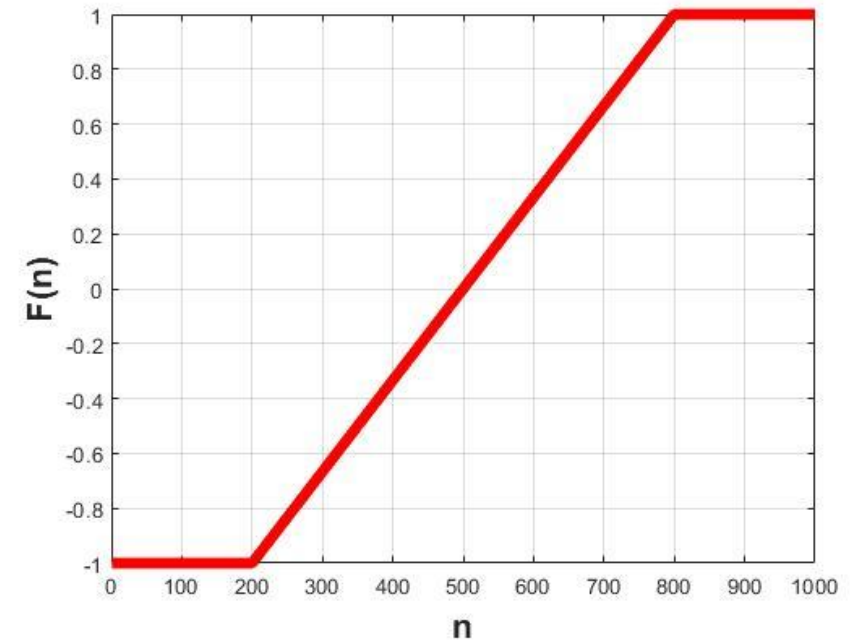

Bochenek B., Mazur M. (2016), Novel Heuristic Algorithm for Compliance Topology. Engineering Transactions 64(4), 1-6.

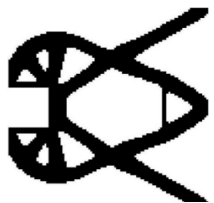

# Cellular Automata as an optimization tool

## Update rule

$$f(n) = C_{\alpha} \frac{\tanh\left[\beta\left(\frac{n - N_1}{N_2 - N_1} - \frac{1}{2}\right)\right]}{\tanh\left(\frac{1}{2}\beta\right)}$$

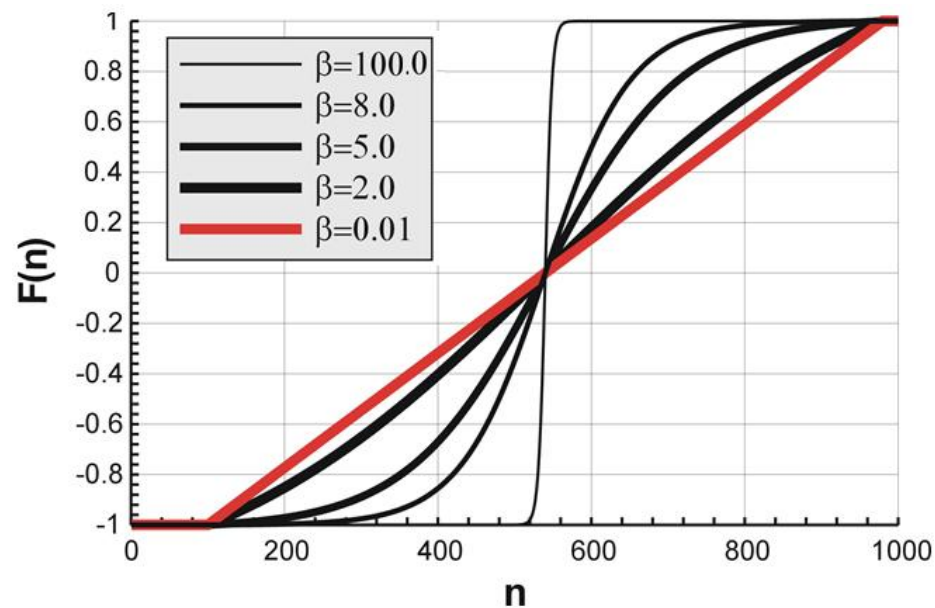

Tajs-Zielińska K., Bochenek B. (2021), Topology algorithm built as an automaton with flexible rules, Bulletin of the Polish Academy of Sciences. Technical Sciences, 69(5), pp. 17.



# Example - the gripper-like structure

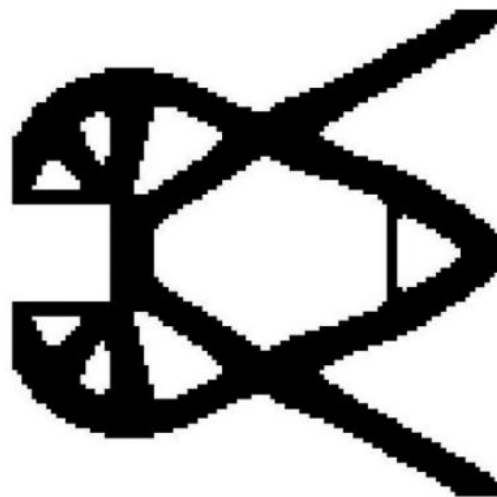
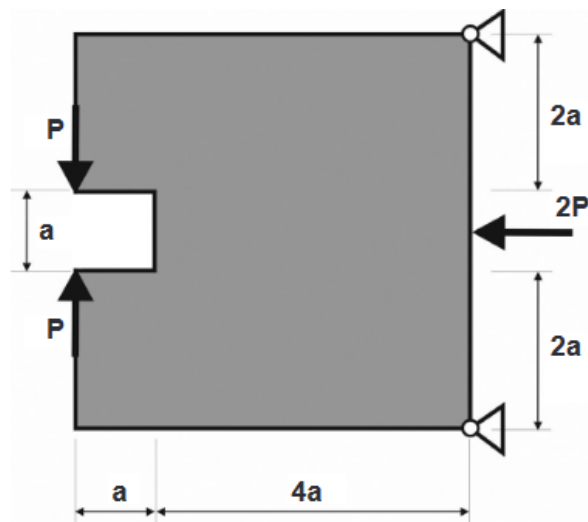

The value of compliance [Nmm] obtained while implementing the FCA algorithm - **26.84 Nmm**  
E. Andreassen, A. Clausen, M. Schvenels, B.S. Lazarov, and O. Sigmund, "Efficient topology optimization in Matlab using 88 lines of code," Struct. Multidiscip. Optim., vol. 4, pp. 1–16, 2011. - **27.59 Nmm**

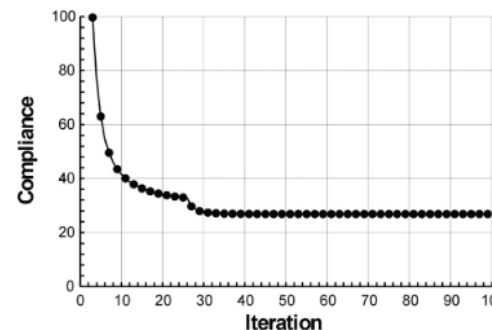
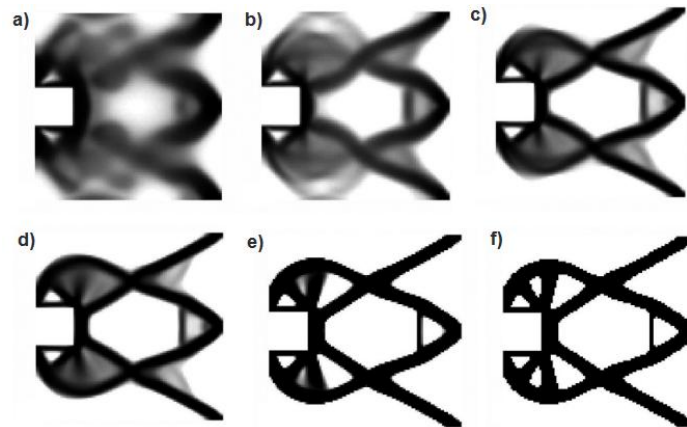

Compliance history

An overview of the topology generation process.  
The middle topologies for iterations 2 (a), 4 (b), 10 (c),  
20 (d), 30 (e) and 100 (f), respectively

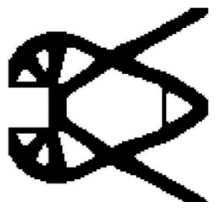

# Periodic structures

---

Periodic structures or quasi-periodic structures, which introduce a certain degree of irregularity, have been studied for their potential to optimal design by offering unique advantages.

Recent investigations illustrate that periodic macrostructures are of more unique in certain cases or enhanced overall mechanical performance than nonperiodic structures and their application in mechanics is encouraging.

One of the greatest advantage is an ease of manufacture and assembly.

Periodic structures are widely used in various fields such as materials science, electronics, optics, chemistry, physics, architectural design and construction.

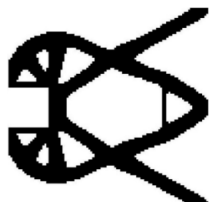

# Periodic structures

Periodic structures or quasi-periodic structures, which introduce a certain degree of irregularity, have been studied for their potential to optimal design by offering unique advantages.

Recent investigations illustrate that periodic macrostructures are of more unique in certain cases or enhanced overall mechanical performance than nonperiodic structures and their application in mechanics is encouraging.

One of the greatest advantage is an ease of manufacture and assembly.

Periodic structures are widely used in various fields such as materials science, electronics, optics, chemistry, physics, architectural design and construction.

## The beauty of repetition in architecture.



<https://threadinburgh.scot/2023/10/09/the-thread-about-the-building-of-the-south-bridge-a-remarkable-feat-of-engineering-and-town-planning-and-one-which-you-mostly-cannot-see/>



<https://photos.com/featured/repetition-in-modern-architecture-just-one-film.html>

<https://www.facebook.com/yonsei.eng/photos/a.123754224501069/943237495886067/?type=3>

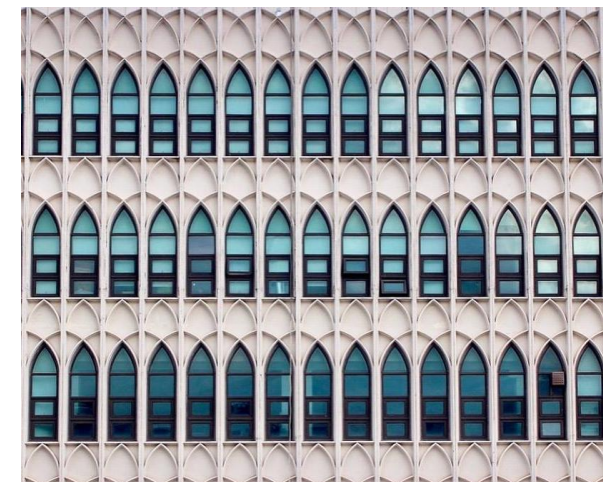

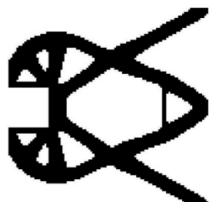

# Periodic structures

## Topology optimization contribution in design principles



<https://pl.freepik.com/darmo-we-zdjecie-wektory/seamless-pattern>

### Pattern

#### For example:

Liu Y., Li Z., Wei P., Wang W.

A novel multi-pattern control for topology optimization to balance form and performance needs.

Engineering Structures, 303 (2024).

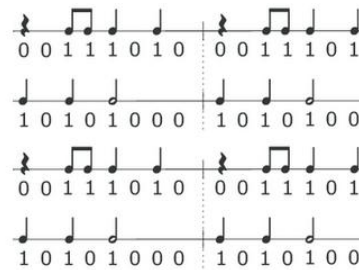

### Rythm

#### For example:

Liu Y., Li Z., Wei P., Wang W.

Parameterized level-set based topology optimization method considering symmetry and pattern repetition constraints. Comput. Methods Appl. Mech. Engrg., 340 (2018), pp. 1079-1101.

## Repetition and periodicity

Repetition of properties at regular intervals is known as periodicity.

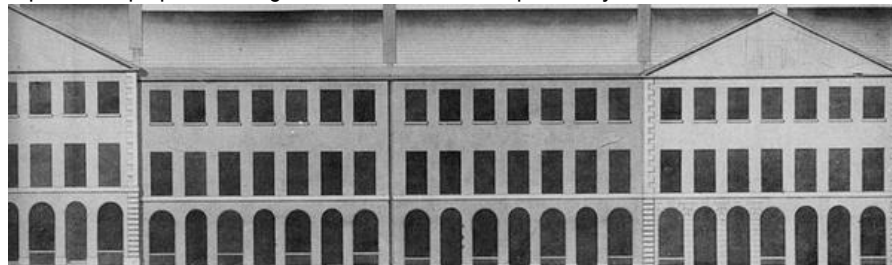

#### For example:

... this presentation

<https://threidinburgh.scot/2023/10/09/the-thread-about-the-building-of-the-south-bridge-a-remarkable-feat-of-engineering-and-town-planning-and-one-which-you-mostly-cannot-see/>

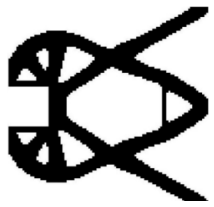

# Topology optimization of periodic structures

---

## Remarks:

Topology optimization of macroperiodic structures is traditionally realized by imposing periodic constraints on the global structure. To consider the periodicity of structure, a given design domain is divided into  $i \times j$  subdomains on the horizontal and vertical directions

but not always, see e.g. Fukada, Y. Formation of periodic ribbed or lattice structures in topology optimization assisted by biological pattern formation. *Struct Multidisc Optim* 61, 1171–1185 (2020).

Those constraints have significant influence of the value of the final compliance (the introduction of periodicity itself and the configuration) – illustration on slide no. 26

Requirements: connectivity between different optimized unit cells needs to be guaranteed.



# Topology optimization of periodic structures

## Minimization of compliance subject to a total volume constraint

### Minimization of compliance

$$\text{minimize } U(d_{i,j}) = \sum_{i=1}^n \sum_{j=1}^m (d_{i,j})^p \mathbf{u}_{i,j}^T \mathbf{k}_i \mathbf{u}_{i,j}$$

$$\text{subject to } 0 < d_{min} \leq d_{i,j} \leq 1$$

$$d_{1,j} = \dots = d_{i,j} = \dots = d_{m,j}$$

To make each sub domain have a periodic topology configuration, a constraint condition is set up in the mathematical model.

### Total volume constraint (set globally, checked after each iteration)

$$V(\mathbf{d}) = \kappa V_0 = \sum_{i=1}^n \sum_{j=1}^m d_{i,j} v_{i,j}$$

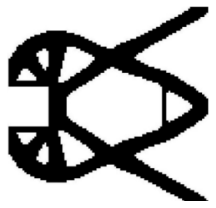

# Topology optimization of periodic structures

---

## Plane structure - initial structure, applied loads and supports

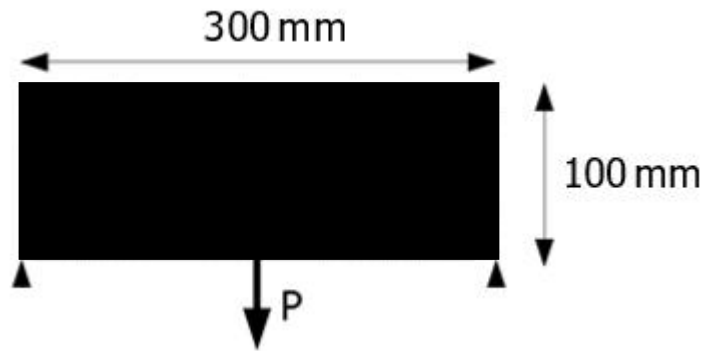

regular mesh of 30 000 elements  
Young modulus  $E = 10$  MPa  
Poisson ratio  $\nu = 0.35$   
volume fraction 0.4



# Topology optimization of periodic structures

## Plane structure - initial structure, applied loads and supports

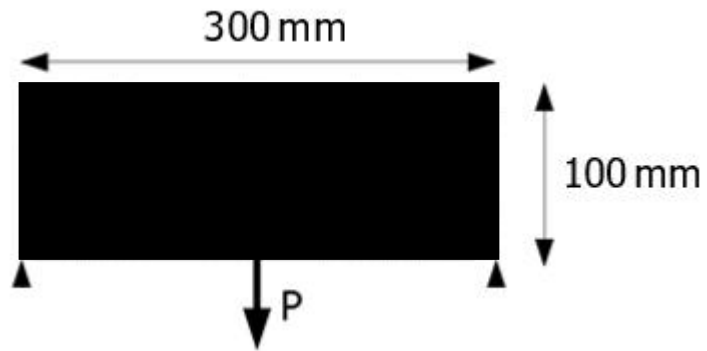

regular mesh of 30 000 elements  
Young modulus  $E = 10$  MPa  
Poisson ratio  $\nu = 0.35$   
volume fraction 0.4

No periodicity



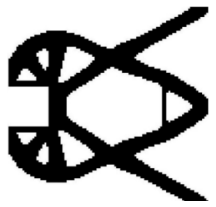

# Topology optimization of periodic structures

---

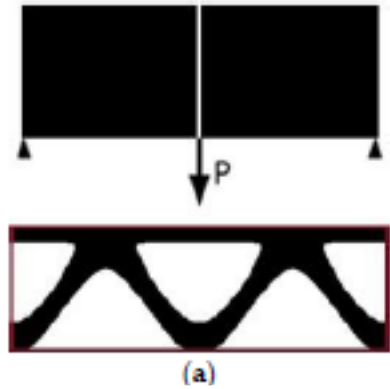

Periodicity schemes: small difference - significant influence of the resulting structure

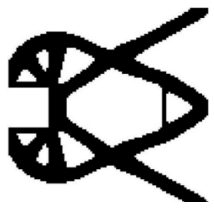

# Topology optimization of periodic structures

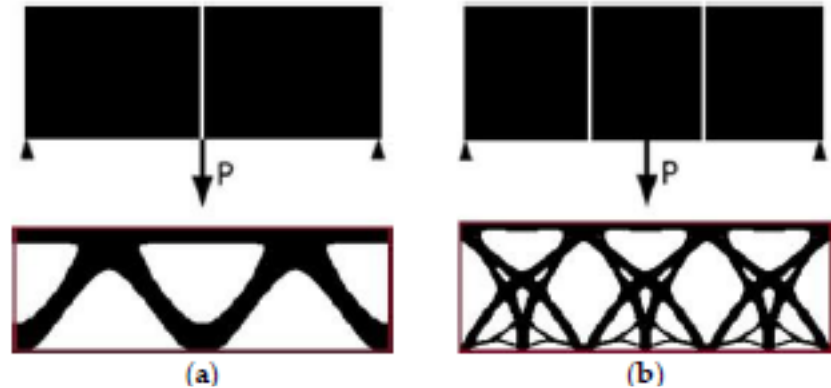

Periodicity schemes: small difference - significant influence of the resulting structure

Periodicity schemes and final topologies for example 1 considering concentrated, external load  $P$  only (red line shows an initial design space for convenience): **(a)** periodicity scheme I: 2 subdomains (final compliance: 21,814 Nmm); **(b)** periodicity scheme II: 3 subdomains (final compliance: 35,710 Nmm); **(c)** periodicity scheme III: 4 subdomains (final compliance: 30,829 Nmm); **(d)** periodicity scheme IV: 5 subdomains (final compliance: 37,199 Nmm).

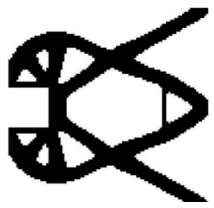

# Topology optimization of periodic structures

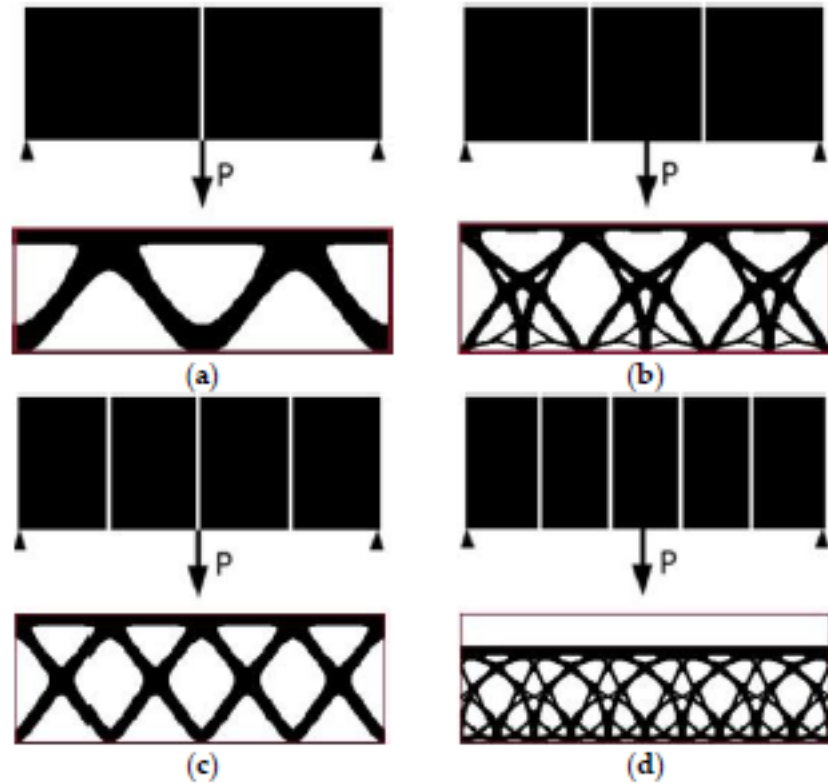

Periodicity schemes: small difference - significant influence of the resulting structure

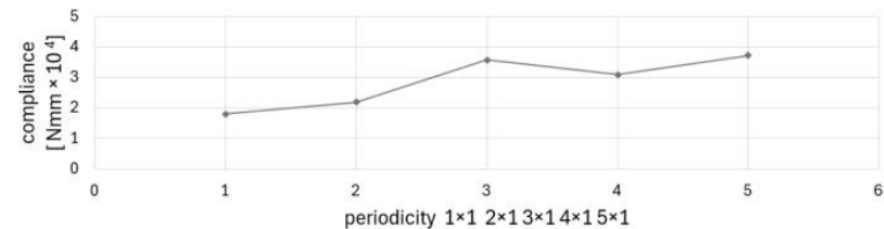

Periodicity schemes and final topologies for example 1 considering concentrated, external load  $P$  only (red line shows an initial design space for convenience): **(a)** periodicity scheme I: 2 subdomains (final compliance: 21,814 Nmm); **(b)** periodicity scheme II: 3 subdomains (final compliance: 35,710 Nmm); **(c)** periodicity scheme III: 4 subdomains (final compliance: 30,829 Nmm); **(d)** periodicity scheme IV: 5 subdomains (final compliance: 37,199 Nmm).

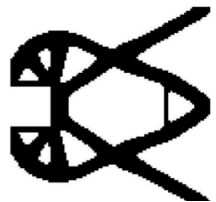

# Topology optimization of periodic structures addressed to massive periodic structures

---

**Motivation - large civil structures, where self-weight plays a significant role in the loading scheme**

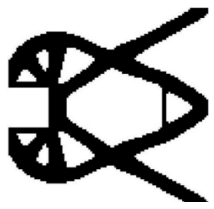

# Generation of structural topologies applied load and self-weight

design-dependent loads: *structural self-weight* (thermo-elastic loads, surface pressure loads, centrifugal loads)

Topology optimization of structures under design-dependent loads is very challenging because it cannot be treated as an extension of standard formulation of topology optimization under fixed load. Considering the self-weight in the optimization process can strongly influence the optimal topologies.

## **Modified SIMP approach** Solid Isotropic Material with Penalization

$$E_i = d_i^p E_0$$

$$\rho_i = d_i^p \rho_0$$

The Young modulus and material density of a cell modelled as functions of relative density

$E_0, \rho_0, p$  Elastic modulus, relative density of material and penalization power

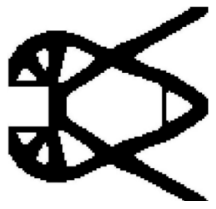

# Generation of structural topologies applied load and self-weight

---

## Plane structure - initial structure, applied loads and supports

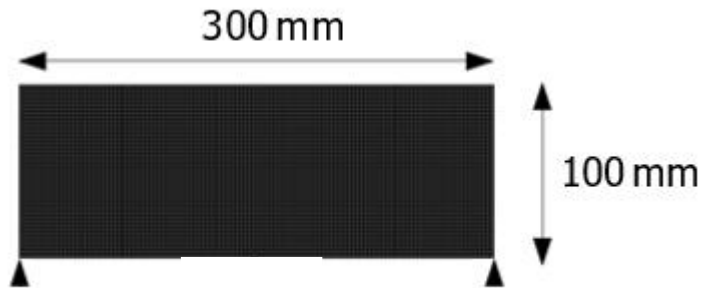

regular mesh of 30 000 elements  
Young modulus  $E = 10 \text{ MPa}$   
Poisson ratio  $\nu = 0.35$   
material density  $\rho = 1000 \text{ kg/m}^3$   
volume fraction 0.4  
gravitational acceleration  $9.81 \text{ m/s}^2$



# Generation of structural topologies applied load and self-weight

---

**NO PERIODICITY**



final compliance 6758 Nmm

Final topology.  
No applied load, self-weight only

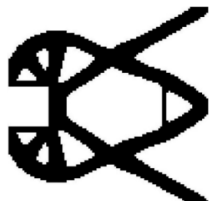

# Generation of structural topologies applied load and self-weight

## NO PERIODICITY



final compliance 6758 Nmm

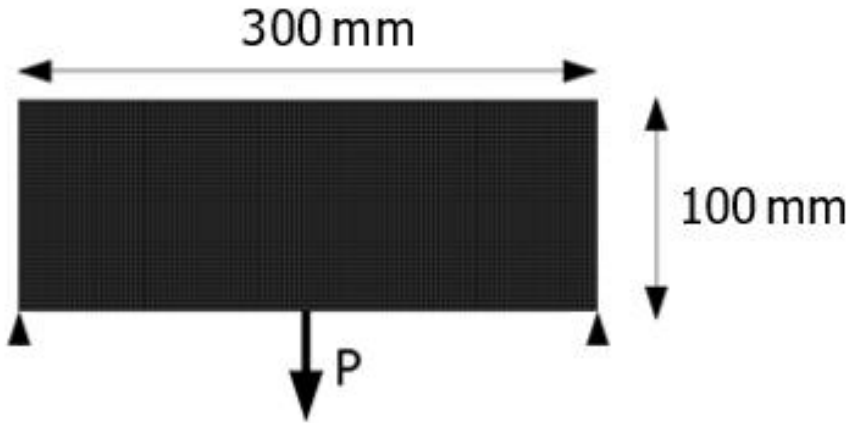

Final topology.  
No applied load, self-weight only

Final topology  
Self-weight included

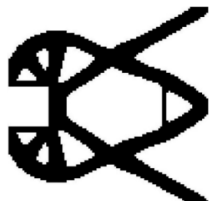

# Generation of structural topologies applied load and self-weight

---

## NO PERIODICITY



final compliance 6758 Nmm

Final topology.  
No applied load, self-weight only



P=10N  
final compliance 10240 Nmm

Final topology  
Self-weight included

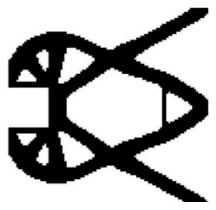

# Generation of structural topologies applied load and self-weight

## NO PERIODICITY



final compliance 6758 Nmm

Final topology.  
No applied load, self-weight only



P=10N  
final compliance 10240 Nmm



P=20N  
final compliance 13476 Nmm

Final topology  
Self-weight included

*Optimization results for a combination of design-independent external and self-weight load depend on the load values ratio.*

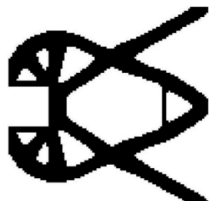

# Generation of structural topologies applied load and self-weight

## NO PERIODICITY



final compliance 6758 Nmm

Final topology.  
No applied load, self-weight only



P=10N  
final compliance 10240 Nmm



P=20N  
final compliance 13476 Nmm

Final topology  
Self-weight included

*Optimization results for a combination of design-independent external and self-weight load depend on the load values ratio.*



final compliance 708 Nmm

Final topology  
No self-weight

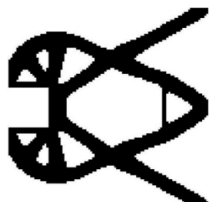

# Topology optimization addressed to massive periodic structures

---

## Periodic structure

### Plane structure - initial structure, applied loads and supports

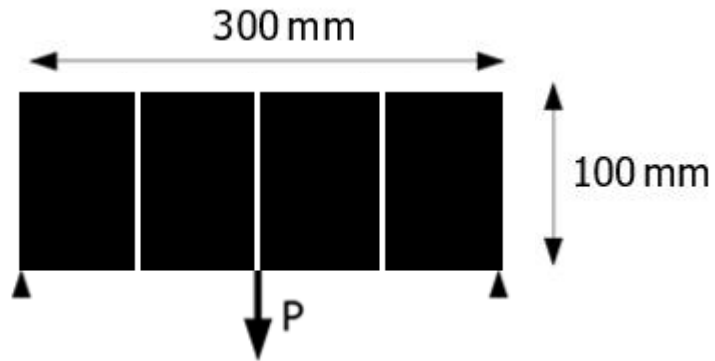

regular mesh of 30 000 elements  
Young modulus  $E = 10$  MPa  
Poisson ratio  $\nu = 0.35$   
material density  $\rho = 1000$  kg/m<sup>3</sup>  
volume fraction 0.4  
gravitational acceleration 9.81 m/s<sup>2</sup>

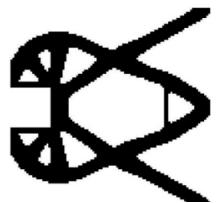

# Topology optimization addressed to massive periodic structures

---



Final topology (1194 Nmm)  
No self-weight



# Topology optimization addressed to massive periodic structures

---



Final topology (1194 Nmm)  
No self-weight



Final topology (26056 Nmm)  
Self-weight included

*Optimization results for a combination of design-independent external and self-weight load depend on the load values ratio.*



Final topology (17316 Nmm)  
No applied load, self-weight only

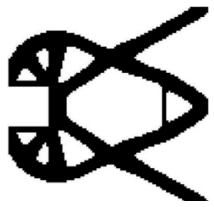

# Topology optimization addressed to massive periodic structures

NO PERIODICITY

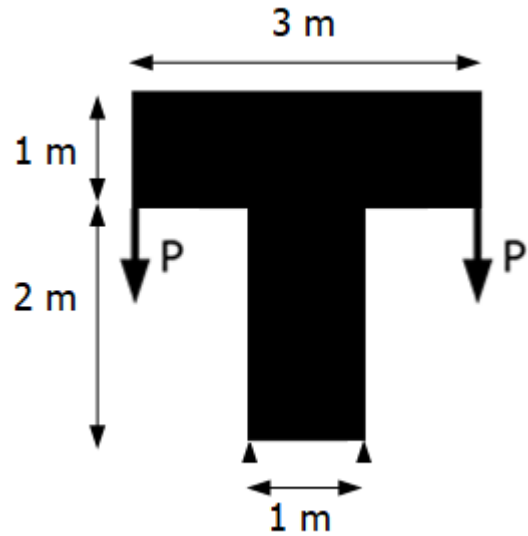

regular mesh of 12 500 elements  
Young modulus  $E = 10$  MPa  
Poisson ratio  $\nu = 0.3$   
material density  $\rho = 1000$  kg/m<sup>3</sup>  
volume fraction 0.4  
gravitational acceleration 9.81 m/s<sup>2</sup>

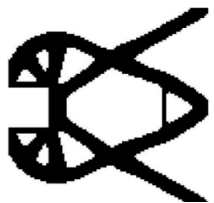

# Topology optimization addressed to massive periodic structures

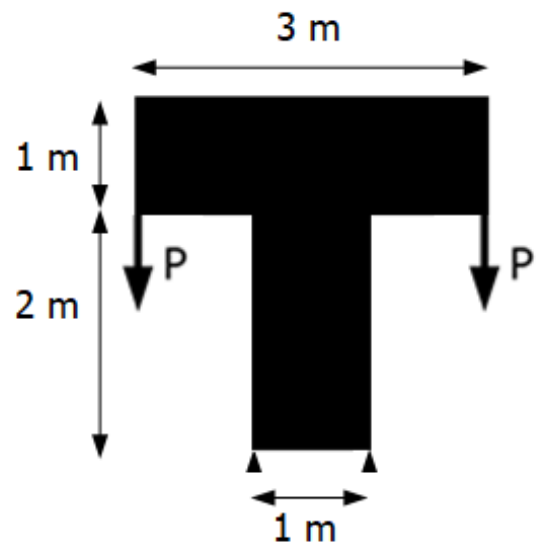

**NO PERIODICITY**  $P=0.00025 \text{ N}$

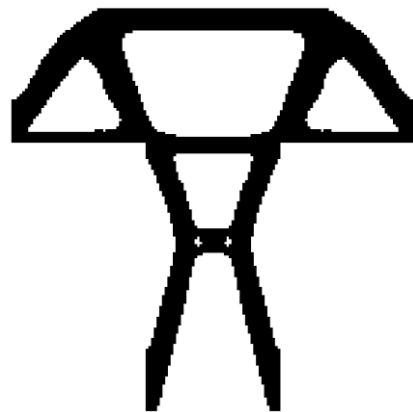

Final topology ( $6.686 \cdot 10^{-5} \text{ Nm}$ )  
No self-weight

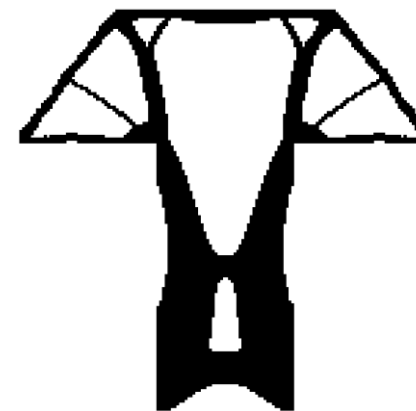

Final topology ( $1.883 \cdot 10^{-4} \text{ Nm}$ )  
Self-weight included

*Optimization results for a combination of design-independent external and self-weight load depend on the load values ratio.*

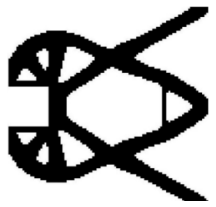

# Topology optimization addressed to massive periodic structures

**PERIODIC SUBDOMAINS**

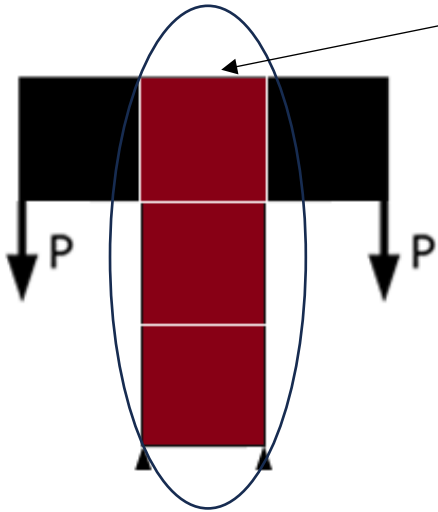

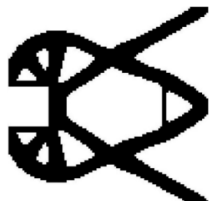

# Topology optimization addressed to massive periodic structures

## PERIODIC SUBDOMAINS $P=0.001 N$

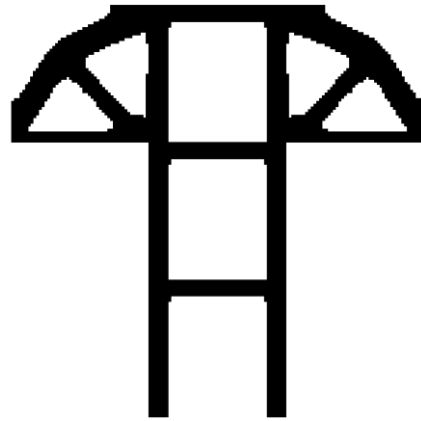
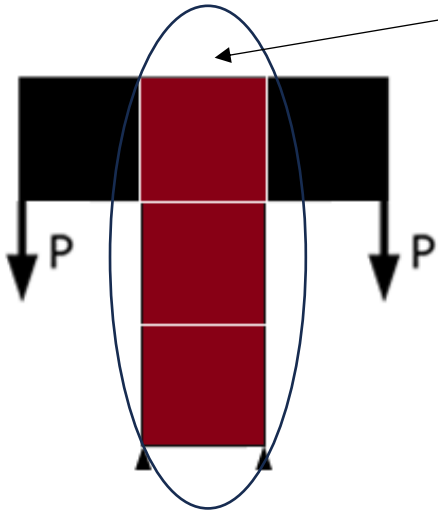

Final topology ( $1.201 \cdot 10^{-4}$ )

No self-weight

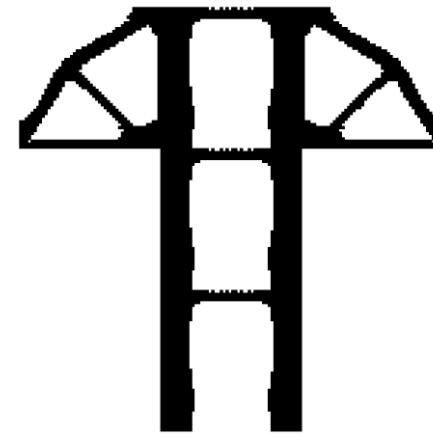

Final topology ( $3.735 \cdot 10^{-4}$ )

Self-weight included

*Optimization results for a combination of design-independent external and self-weight load depend on the load values ratio.*



# Topology optimization addressed to massive periodic structures

## PERIODIC SUBDOMAINS

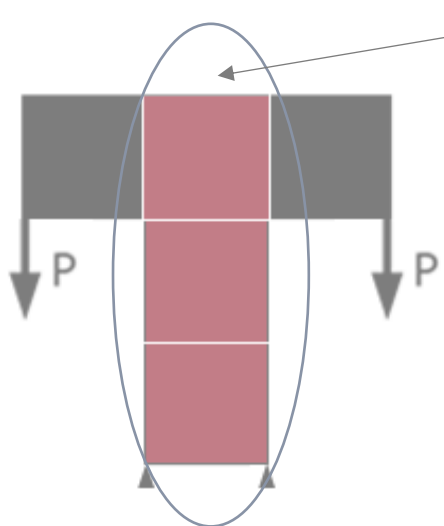

Final topology  
No self-weight



Final topology  
Self-weight included

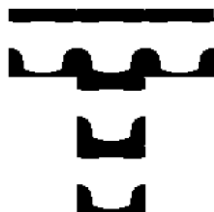

Algorithm has not found the final results for the example, when all subdomains are periodic.

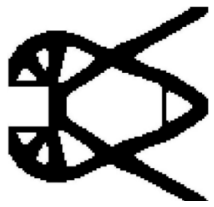

# Topology optimization addressed to massive periodic structures

Engineering example: T-beam (8 segments)

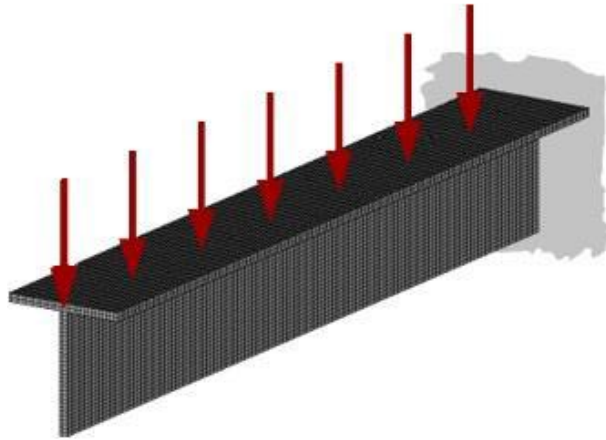

regular mesh of 12 000 elements  
Young modulus  $E = 10$  MPa  
Poisson ratio  $\nu = 0.3$   
material density  $\rho = 7500$  kg/m<sup>3</sup>  
volume fraction 0.4  
gravitational acceleration 9.81 m/s<sup>2</sup>

- a unique case
- non-optimized region (shell of a T-beam)

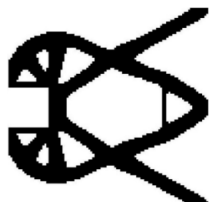

# Topology optimization addressed to massive periodic structures

Engineering example: T-beam (8 segments)

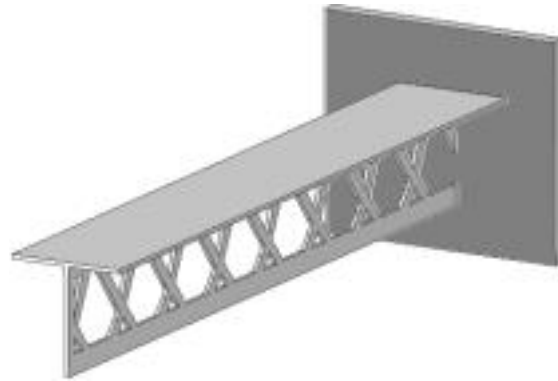
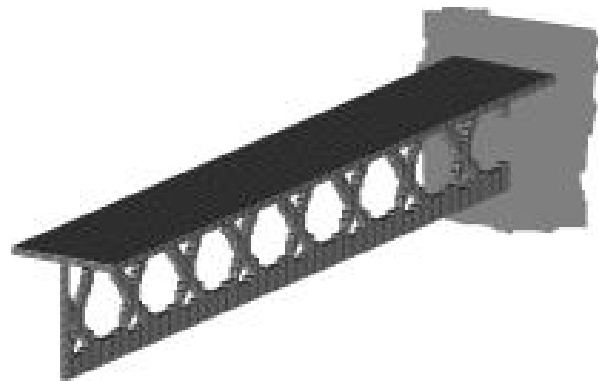
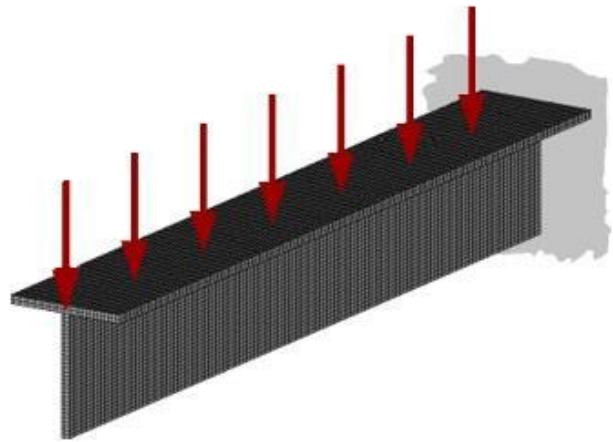

- a unique case
- non-optimized region (shell of a T-beam)

Final topology, force = 100 kN ( $658 \cdot 10^6$  Nm)



Final topology ( $628 \cdot 10^6$  Nm)  
No applied load, self-weight only



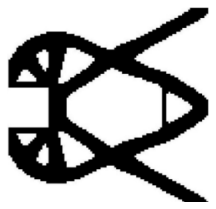

# Topology optimization addressed to massive periodic structures

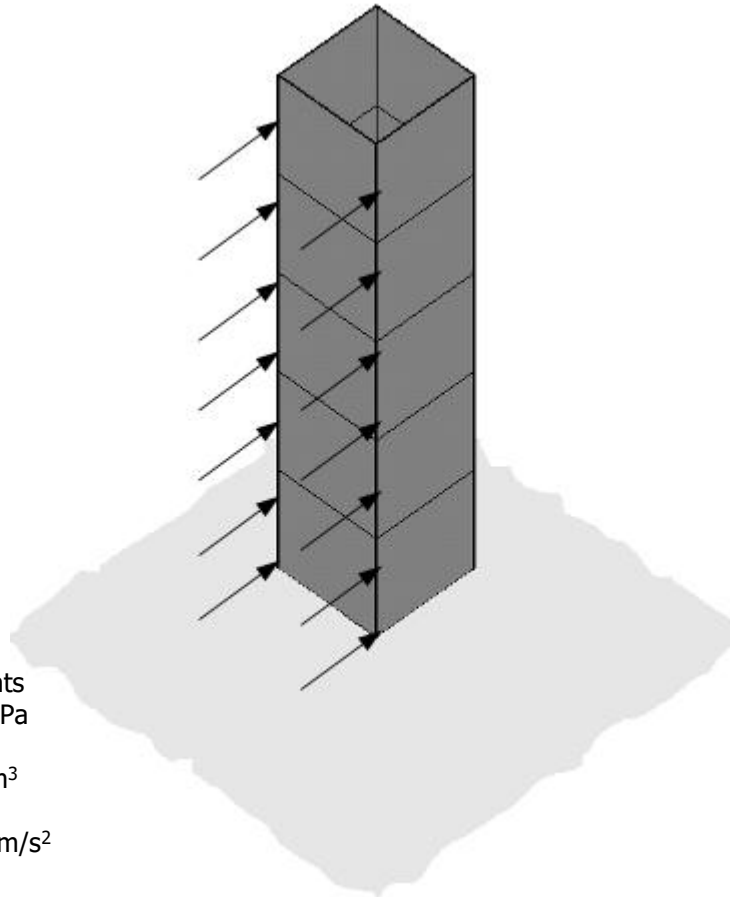
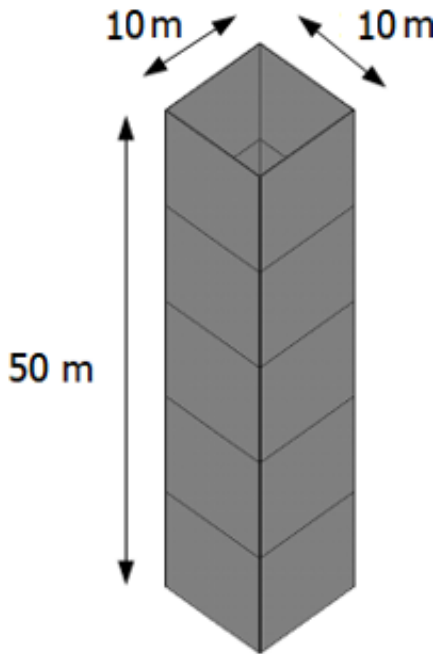

regular mesh of 32 800 elements  
Young modulus  $E = 200 \cdot 10^9$  Pa  
Poisson ratio  $\nu = 0.35$   
material density  $\rho = 7500$  kg/m<sup>3</sup>  
volume fraction 0.4  
gravitational acceleration 9.81 m/s<sup>2</sup>

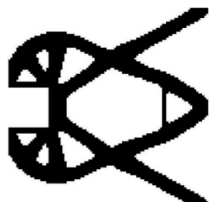

# Topology optimization addressed to massive periodic structures

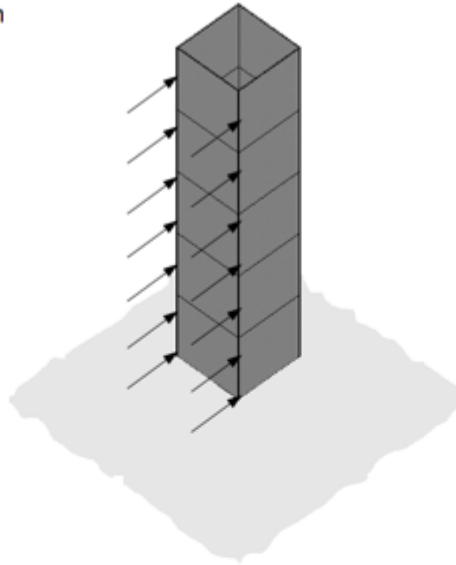
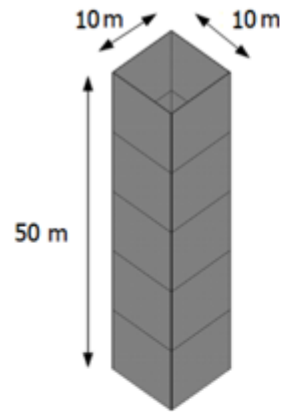

Final topology  
No self-weight  
 $6.703 \cdot 10^{-3}$  Nm

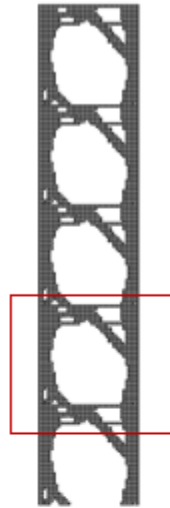

Final topology  
- front view

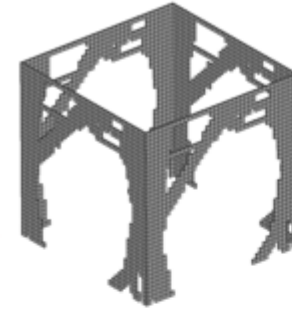

Final topology  
- one segment



Final topology  
Self-weight included  
 $187 \cdot 10^3$  Nm

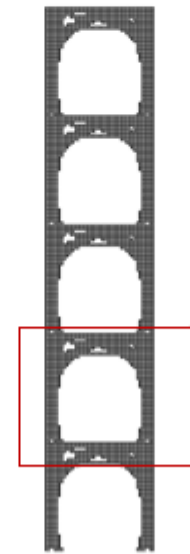

Final topology  
- front view

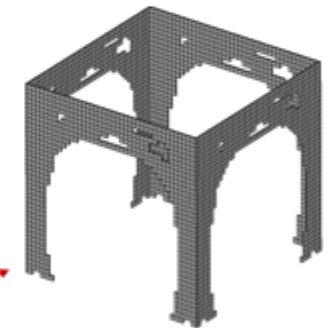

Final topology  
- one segment

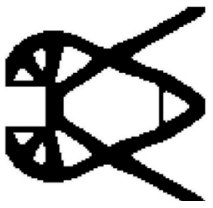

# Conclusions

---

- **The concept of Cellular Automata arranged to topology optimization addressed to massive periodic structures has been proposed.**
- **The results of the performed tests confirmed that the CA algorithm has the ability to cope with generation of topologies for periodic structures, what proves versatility and flexibility of the algorithm/method/concept.**
- **It does not require any additional density filtering to generate black-and-white topologies (without grey regions), what is important for manufacturing-friendly designing.**
- **The new application i.e. consideration a topology optimization of periodic structures under self-weight loading was investigated and illustrated with numerical examples.**

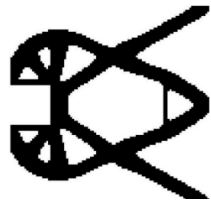

Thank You for Your kind attention

K. Tajs-Zielińska

Cracow University of Technology, Poland

Corresponding author e-mail: [katarzyna.tajs-zielinska@pk.edu.pl](mailto:katarzyna.tajs-zielinska@pk.edu.pl)